



NORWICH
UNIVERSITY[®]

Commuter
Student Guidebook

2019-2020

TABLE OF CONTENTS

1. NORWICH LEADERSHIP

A Message from the President
A Message from the Provost
Senior Vice President for Student Affairs and Technology
Dean of Students
Civilian Student & Corps of Cadets - Student Affairs Organizational Chart

2. ESSENCE OF NORWICH UNIVERSITY

Guiding Values
Vision Statement
Mission Statement, 1843 Catalogue
Institutional Priorities
Student Oath
University Motto
Honor Code
University Lingo

3. NORWICH UNIVERSITY HISTORY

Alden Partridge
Selected History of Norwich University
Selected History of Vermont College
Norwich Medal of Honor Recipients
Norwich Forever

4. ACADEMICS & STUDENT SUPPORTS

Academics
Academic Expectations
Vermont State Militia (VSM) Uniform
Academic Achievement Center
CAM (Corporal/Civilian Academic Mentoring) Program
Career & Internship Center
Counseling & Wellness Center
Diversity, Equity and Inclusion Office, Title IX Coordinator
Honors Program
Infirmary/Norwich University Health Services
Information Technology Services
International Center
Kreitzberg Library
Registrar's Office
Religious Services
Writing Center
You and Your Academic Advisor

5. COMMUTER STUDENT LIFE

General
Off-Campus Housing
Registration of Local Address and Phone
Campus Services for Commuter Students

Parking and Car Registration
Inclement Weather Policy
Ring Policy

6. THE CORPS OF CADETS

The Corps of Cadets and Rookdom
Military Formations/Ceremonies & Common Courtesies
Upper Parade Ground (UP)
Military/Corps of Cadets Vernacular
Military Time
Corps of Cadets Organizational Chart

7. ACTIVITIES & INVOLVEMENT

Athletics/Recreational Facilities
Campus Activity Board
Center for Civic Engagement
Leadership Development Program
Shaw Outdoor Center
Student Clubs
Student Government Association

8. CAMPUS SERVICES

Barber Shop
Bursar
Cadet\$Card
Dining & Catering Services by Sodexo
Fitness Center, Goodyear Pool, & Kreitzberg Ice Arena
Laundry Services through the Uniform Store
Mailroom
Public Safety
Student Financial Planning
Emergency and Important Numbers

9. UNDERGRADUATE CALENDAR

10. NU EMERGENCY 24- HOUR PHONE NUMBERS

NORWICH LEADERSHIP

A Message from the President

As a Norwich student, you have embarked on what will be the most intense, rewarding four years of your life. A Norwich experience is unique and special. And you, as a student at our nation's oldest senior military college, are also different. You want a remarkable life, filled with purpose and passion. Our mission is to help you develop as an empathetic leader of character with impeccable integrity, cross-cultural intelligence, and multi-cultural agility. We are committed to fostering your growth intellectually, physically, morally and ethically through transformative educational and leadership experiences.

At Norwich University, we have been educating leaders since 1819. Our students achieve at the highest level, in and out of the classroom. We are committed to fostering your growth intellectually, physically, morally and ethically. Your professors will push the boundaries of creativity and innovation to provide you an education that prepares you to lead in a career you will love.

Norwich student's lead two different lifestyles yet stand together with the same ideals and honor code. The Honor Code is simple and is the minimum standard of ethical behavior for all Norwich students. I expect you to live by this honor code every day as a member of our community.

You are holding in your hands the seventh edition of this student handbook. While some of this information is addressed in the University Rules and Regulations, this handbook also contains information to help you understand the unique aspects of Norwich which you will never experience at another college or university.

We welcome your input and appreciate your suggestions to make this handbook more useful. We look to the class of 2023 to improve this publication for the class of 2024 and those who follow in your footsteps. Best of luck to you as you begin this new chapter of your life as a student at Norwich University. Follow your dreams to serve and to succeed, fully understanding what it means to be a global citizen and make a tangible difference in the 21st century.

Norwich Forever!



Richard W. Schneider
RADM, USCGR (Ret.)
President

RADM Richard W. Schneider, USCGR (Ret.), PhD
23rd President of Norwich University

One of the longest seated college presidents in the country, Dr. Richard W. Schneider proudly carries on the tradition Norwich University founder Captain Alden Partridge began 200 years ago of preparing "citizen soldiers" to serve our nation. Through his experience in the military and academia, as well as his service in the U.S. Coast Guard, Dr. Schneider epitomizes Norwich's unique position in American higher education as a senior military college and birthplace of the Reserve Officers' Training Corps.

A native of Queens, New York, Dr. Schneider is a 1968 graduate of the U.S. Coast Guard Academy. He was commissioned as an ensign in the Coast Guard and served eight years of active duty, including a tour

of Vietnam. Dr. Schneider retired from the Coast Guard Reserve as a Rear Admiral in July 1998.

In July 1992, Dr. Schneider became the 23rd President of Norwich University. Since then, he has championed Norwich's charge to distinguish the University in the marketplace of higher education institutions by educating students to be global leaders in the private sector, government and the military.

A Message from the Provost

It is my very great pleasure to welcome you to Norwich University. I am honored to be part of this great institution and delighted to join the President and his strong leadership team as we move Norwich forward in service to our students, our nation, and the world.

Norwich University's foundation is strong because of our mission and values committed to honor, integrity, perseverance, and service to others through inclusive leadership. Here you will discover an outstanding faculty and professional staff who provide transformational teaching and learning experiences across a range of academic programs that are well aligned the career opportunities of today and tomorrow.

Our commitment is to your success, and our work is dedicated to ensuring Norwich continues to be a place where creative problem-solving, intellectual inquiry, and hands-on experiences of lasting importance are the norm for every student. We count on you to help us reach that goal: very little can happen without the enthusiasm and participation of the students for whom Norwich exists. Each of you contributes to the University in your own way, adding new threads to the ever-evolving fabric of our community – a fabric that we are making together from the resources of our diverse experiences, aspirations, and achievements. There are countless ways to make good use of your time at Norwich, and each begins with curiosity, a willingness to seek out new experiences and new people, and a sincere desire to make your mark.

I am confident in your ability to excel here at Norwich and beyond.

Norwich Forever!



Dr. Sandra M. Affenito
Provost and Dean of Faculty

Sandra G. Affenito, PhD, R. D, FAND **Provost and Dean of the Faculty**

As Provost and Dean of the Faculty at Norwich University, Dr. Sandra G. Affenito leads program and curriculum development, assessment, accreditation, strategic and financial planning, community partnerships, and the development, maintenance, and growth of the University's academic program, infrastructure, and capacity. With a genuine commitment to inclusive excellence, high-impact practices, and engaged learning, she supports the professional development of faculty and academic staff in their teaching, scholarly, and research activities.

Dr. Affenito holds a Ph.D. in Nutritional Sciences from the University of Connecticut. She completed post-doctoral training in Biomedical and Behavioral Sciences at Wesleyan University through the National Institutes of Health, Office of Women's Health and is a 2012 alumna of the HERS (Higher Education Resource Services) Institute for Women in Higher Education Administration, Wellesley College, as well

as a 2015 graduate of the Institute for Management and Leadership in Education at Harvard University. Collectively, she has over thirty-five years of leadership and administrative experience in higher education, health care, and the corporate sector; this background has provided for diverse leadership experiences across a variety of functions and units.

Throughout her career, Dr. Affenito has had an active academic agenda as a teacher, scholar, and bio-behavioral research scientist. Currently, her scholarly work focuses on understanding the ever-evolving higher education environment to plan and lead through change in the Academy. Dr. Affenito has a distinguished record of professional and community service, most recently focused on the American Council of Education (ACE) Women's Network as well as ACE Inclusive Excellence.

Frank Vanecek, DBA

Senior Vice President for Student Affairs and Technology (SVPSAT)
Professor of Computer Science

Arriving at Norwich University in 1976, Dr. Vanecek is beginning his 43th year of service. Prior to his current appointment as Senior Vice President for Student Affairs and Technology, Dr. Vanecek served for two years as the University's Interim Vice President for Academic Affairs from 2008 to 2010.

Martha Mathis, EdD

Dean of Students

Dean Mathis was the Dean of Students at Vermont College and moved to the Norwich Campus in 1993 with the civilian students. As the Dean of Students at Norwich University she oversees Residence Life, the Associate Dean of Students, and the discipline process for the civilian lifestyle. She is here to support the success of all Norwich students.

Civilian Student & Corps of Cadets - Student Affairs Organizational Chart

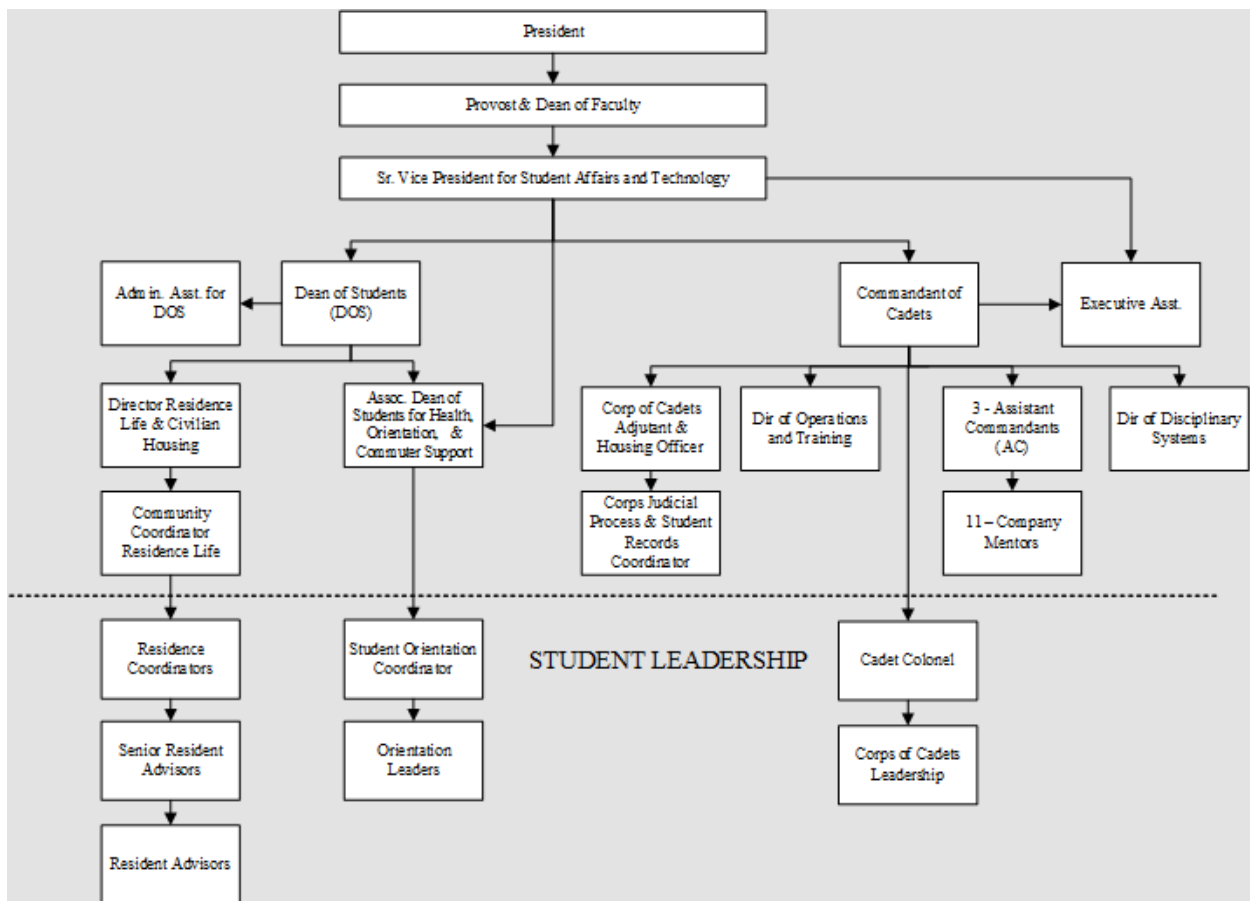

ESSENCE OF NORWICH UNIVERSITY

Guiding Values

- We are men and women of honor and integrity. We shall not tolerate those who lie, cheat, or steal.
- We are dedicated to engaged teaching and learning, emphasizing teamwork, leadership, creativity, and critical thinking.
- We respect and embrace diverse points of view as a cornerstone of our democracy.
- We encourage service to nation and others before self.
- We stress being physically fit and drug free.
- To live the Norwich motto, — “I will try!” — meaning perseverance in the face of adversity.
- We stress self-discipline, personal responsibility, and respect for law.
- We hold in highest esteem our people and reputation.

Vision Statement

Norwich University will be a learning community, American in character yet global in perspective, engaged in personal and intellectual transformation and dedicated to knowledge, mutual respect, creativity and service.

Mission Statement, 1843 Catalogue

To give our youth an education that shall be American in its character to enable them to act as well as to think to execute as well as conceive “to tolerate all opinions when reason is left free to combat them” to make moral, patriotic, efficient, and useful citizens, and to qualify them for all those high responsibilities resting upon a citizen of this free republic.

Institutional Priorities

- Innovative Teaching and Learning
- Interdisciplinary Collaboration
- Inspire Students
- Inclusive Leadership
- Information Technology
- Internationalization
- Invest Strategically

Student Oath

I..., will henceforth strive to live by the Norwich Guiding Values.

As a student at Norwich University, I promise to accept and apply the principles of the honor code and guiding values; to abide by the Norwich University Rules and Regulations; to obey the legal orders of Norwich Officials; to foster the Norwich Spirit; and to uphold the traditions of my Alma Mater.

In all my endeavors from this day forth I will reflect the spirit of the Norwich motto, I WILL TRY

University Motto

The Norwich University motto, “I will try”, was inspired by one of the most significant victories by the Army during the War of 1812. At the Battle of Lundy’s Lane, Infantry Regiment, was directed by Brig. General Jacob Brown to make a difficult nighttime frontal assault against a British artillery battery positioned on a hill near the Niagara River in Canada. COL Miller’s response was “I’ll try, sir.”

After two unsuccessful attempts, Miller rallied the remnants of his regiment and was finally successful in a fierce assault that brought the muskets of the opposing forces so close that they were fighting muzzle-to-muzzle. The British were forced to abandon their artillery, wagons and munitions. Thus, COL Miller immortalized himself through his actions and his words. Significantly, Brig. General Brown and Colonel Miller had been senior officers in the militia who were given commissions in the U.S. Army and should be considered role models for future citizen-soldiers.

More recently confusion and misunderstanding has arisen about the source of the Norwich motto. One erroneous tradition is that Truman Bishop Ransom, the second president of Norwich University, coined the motto, “I will try” on September 12th, 1847, while leading his regiment at the Battle of Chapultepec during the Mexican War. A variant of the tradition is that Ransom during the same battle in which he lost his life used the expression “Essayons” (French for “Let’s Try”), the official motto of the U.S. Army Corps of Engineers. There is no evidence to support either of these traditions.

It is clear, however, that the Norwich University motto, “I will try,” was established and in use well before the Mexican War. In fact, it was incorporated into the University seal as early as 1839. The oldest flag of the University, now in the Norwich University Sullivan Museum and History Center, is embroidered on one side with the words “Presented by the Young Ladies of Norwich [Vermont] to the Cadets of Norwich University, August, A.D. 1844.” The other side of the flag displays a version of the University seal emblazoned with the motto “I’ll try.”

“I will try. This means holding firm to timeless values. This means doing the right thing, not when it’s easy, but especially when it is hard. It means citizen-soldiers, selflessly serving America in peace and war. Selfless service to the nation and to each other - that is success. That is the essence of Norwich”
–GEN Gordon R. Sullivan, USA (Ret.) ’59

1992 Commencement Address

The Honor Code

“A student will not lie, cheat, steal, or tolerate those who do.”

In the fall of 1951 an Honor System was formally established at Norwich University. The Norwich University Honor Code is maintained and administered by the Honor Committee comprised of students from the Corps of Cadets and Civilian lifestyles, under the supervision of Director of Judicial Affairs and Ethics and the Sr. Vice President of Student Affairs and Technology.

The Norwich Honor Code provides the foundation for a way of life, and for the development of fundamental attributes of good character. Honor is a virtue which impels personal courage and duty, truthfulness and self-respect, justice and generosity. Its underlying principle is truth. All members of the Norwich community are expected to live by the Code’s standard both at and away from Norwich, in their professional and personal lives.

“He who permits himself to tell a lie once finds it much easier to do it a second and third time, till at length it

becomes habitual; he tells a lie without attending to it and truths without the world believing it.” -Thomas Jefferson

Further information about the University’s Honor Code can be found in the Student Rules and Regulations.

University Terminology

<u>Acronym</u>	<u>Commonly Accepted Meaning</u>
CAM.....	Civilian/Corporal Academic Mentor
CAB.....	Campus Activities Board
DOS.....	Dean of Students
FAT.....	Friday Afternoon Training (for Corps of Cadets)
FLC.....	Future Leader Camp
MCV.....	Military College of Vermont
NUEMS.....	NU Emergency Medical Service
ROTC.....	Reserve Officers’ Training Corps
RA.....	Resident Advisor
RC.....	Resident Coordinator
SRA.....	Senior Resident Advisor
SGA.....	Student Government Association
SADO.....	Student Affairs Duty Officer
SOP.....	Standard Operating Procedures
TAT.....	Tuesday Afternoon Training (for Corps of Cadets)
UP.....	Upper Parade Ground

This list isn’t all-encompassing. Please don’t hesitate to ask faculty or staff members if you are ever unsure of what something means.

NORWICH UNIVERSITY HISTORY

Alden Partridge

February 12, 1785 - January 17, 1854

In the early years of the United States, Capt. Alden Partridge stood at the forefront of a movement to broaden the scope and purpose of higher education. His experiences as a student, and later a cadet, instructor, and administrator of the United States Military Academy at West Point, shaped his understanding of the country's needs for citizens prepared to contribute to the democracy in times of peace and war. Capt. Partridge founded the nation's oldest private military college in 1819, the American Literary, Scientific, and Military Academy which later became Norwich University. His broad curriculum of the sciences and humanities, physical education, and hands on learning coupled with military training formed the vision of Norwich University. Since its establishment, Norwich has continued to produce citizen soldiers who have provided exemplary service to the nation.

- Adapted from text in the Sullivan Museum and History Center

Selected History of Norwich University

1819 - Founded by Captain Alden Partridge at Norwich, Vermont "The American Literary, Scientific, and Military Academy."

1820 - Band organized, oldest collegiate band in the nation. First instruction in Civil Engineering offered in the US.

1834 - Academy received a charter from the State of Vermont recognizing the institution as Norwich University.

1866 - South Barracks at Norwich, Vermont burned; Norwich moved to Northfield, Vermont.

1868 - Old Barracks first university building built in Northfield, Vermont, named Jackman Hall in 1907.

1898 - Norwich designated "The Military College of the State of Vermont" by the Vermont Legislature.

1907 - Carnegie Library constructed, renamed Henry Prescott Chaplin Memorial Library in 1952; Electrical Engineering Department established.

1916 - Reserve Officers' Training Corps established. Norwich designated a Senior Division Cavalry Unit. Harold "Doc" Martin entered Norwich University, the first African American Cadet.

1919 - Centennial Celebration, stairs and gate post erected.

1923 - Class ring tradition started.

1929 - Armory constructed; named Plumley Armory in 1962.

1941 - White Hall erected, and used as a dining hall until 1962 when it was converted to White Memorial Chapel. Partridge Hall constructed.

1943-1946 - University facilities devoted to Army Air Corps Aircrew Training Program, Army Specialized Training Program, and Army Specialized Training Reserve Program; there was no Corps of Cadets.

1951 - Honor System adopted.

1960 - Fraternities abolished; class clubs instituted.

1964 - Jackman Hall, the Old Barracks, demolished.

1965 - Dodge Hall demolished. New Jackman Hall constructed.

1972 - Vermont College purchased.

1974 - First women enter the Corps of Cadets, two years before the Federal Service Academies.

1987 - Jacob Shapiro Field House constructed.

1990 - Five-year baccalaureate degree program in architecture started.

1990 - Civilian junior ring tradition started.

1992 - Norwich Ski Area closed.

1993 - Undergraduate programs at Vermont College moved to Northfield campus; cadet and civilian student populations reside on the same campus for the first time. Kreitzberg Library constructed. GEN Gordon R.

Sullivan '59 promoted to Chief of Staff of the U.S. Army.
1995- Cadet Tracey L. Jones '96, first student selected as a Rhodes Scholar.
1997 - Opening of the Engineering, Math, and Science Complex.
1998 - Kreitzberg Arena constructed on the former site of Taylor Arena
2001- Vermont College sold
2007 - Sullivan Museum and History Center dedicated. Wise Campus Center opens.
2008 - South Hall dormitory opens on Upper Disney Field.
2009 - The Class of 1959 Bridge opens.
2011 - Norwich students called to assist central Vermonters after Tropical Storm Irene flooding from rainfall of up to 8.15'' in Vermont.
2013 – Haynes Family Stadium dedicated. Sabine Field rededicated. New artificial playing field with lights and new recreational running track.
2013 - The old Norwich Ski Area on Paine Mountain is renovated and reopened as the SFC John Shaw Outdoor Center. Sabine Field and Biomass Heating Plant Open.
2014 - Dalrymple Hall opens.
2015 - Kreitzberg Library Renovated
2016 – Centennial celebration as the birthplace of Reserve Officers' Training Corps (ROTC)
2017- Brig Gen Kimberly Baumann '87, first female Norwich general officer.
2018 – Mack Hall is constructed; Ainsworth Hall is renovated.
2019 – North Hall, formerly Webb Hall, is renovated and rededicated. Norwich commemorates its bicentennial. Bicentennial stairs open.

Select History of Vermont College

1832 - Newbury Seminary Proposed, with Alden Partridge in attendance
1834 - Newbury Seminary founded
1849 - Charter granted for the establishment of the Female Collegiate Institute
1865 - Both Newbury Seminary and Female Collegiate Institute combined and renamed to Vermont Conference Seminary and Female College
1870 - Renamed to Vermont Methodist Seminary and Female College
1888 - Renamed to Vermont Methodist Seminary
1894 - Renamed Montpelier Seminary
1941 - Renamed Vermont Junior College
1958 - Renamed Vermont College
1972 - Vermont College and Norwich University merge
1993 - Undergraduate Programs merged at Norwich University. Vermont College students moved onto Norwich Campus, Vermont College campus closed
2001- Vermont College sold.

Norwich Medal of Honor Recipients

The Medal of Honor, established by an act of Congress in 1862, is the highest and most rarely awarded decoration conferred by the United States. Presentation of the Medal of Honor is only made by the President of the United States. Norwich University has eight recipients of this prestigious award. A display for them is available for viewing immediately inside the front main entrance of Jackman Hall.

Henry Clay Wood, Class of 1856

Willie Johnston, Class of 1870

Edmund Rice, Class of 1860

Thomas O. Seaver, Class of 1859

Edward B. Williston, Class of 1856

Hiram Iddings Bearss, Class of 1898

James M. Burt, Class of 1939

Edward Byers, Jr., CGCS Class of 2019

Norwich Forever

Norwich forever, queen of the hills,
When far from thee, still memory thrills recalling Scenes and old friendship, songs and old cheers,
Memories that face not through the changing years. Norwich forever, through rain and shine,
Sunset and dawning, still we are thine and in Defeat or in victory we shall acclaim
Thy dauntless spirit and thy deathless name. Norwich, forever, hail, hail to thee,
Bright is thy glory, won in the long years and we Pledge thee our future, thee to adore
Till in the skies the stars shall burn no more.

Words: Arthur Wallace Peach. Tune: True Blue

ACADEMICS & STUDENT SUPPORTS

Academics

Norwich has a diverse array of majors from which students may choose. The five colleges at the University report to the Provost who is the chief academic officer and the dean of the faculty. Four of these colleges provide the campus based undergraduate courses that students take during fall, spring or summer semesters.

The College of Professional Schools is home to five different schools that provide education necessary to meet the professional degree requirements in the chosen field of study. The David E. Crawford School of Engineering offers degree programs in Civil Engineering, Electrical and Computer Engineering, Engineering, Mechanical Engineering, and Construction Management. The School of Architecture + Art offers a bachelor degree in Architectural Studies and a Master of Architecture. The School of Business offers degrees in Accounting, International Business, and Management. The School of Nursing offers a BSN degree in Nursing. The School of Cybersecurity, Data Science and Computing offers degrees in Computer Science, and Computer Security & Information Assurance.

The College of Liberal Arts is home to four departments, one school and ten different majors. Bachelor's degrees are offered in Communications, Criminal Justice, English, History, International Studies, Political Science, Psychology, Spanish, Studies in War & Peace, and Education. The college also offers minors in Asian Studies, Computer Crime and Forensics, Transnational Crime, Chinese, French, German, Philosophy, Writing, and Sociology.

The College of Science and Mathematics is home to six departments and twelve different programs. Bachelor's degrees are offered in Biochemistry, Biology, Chemistry, Environmental Science, Exercise Science, Geology, Health Science, Mathematics, Neuroscience, Physical Education, and Physics. A master's degree is offered in Athletic Training.

The College of National Services is home to the Army, Air Force, and Navy and Marine Corps ROTC programs. Each student in the Corps of Cadets is required to take a minimum of four semesters of ROTC classes but may take up to eight semesters as space is available. A number of the cadets will commission into one of the four branches of the Armed Services upon graduation.

Academic Expectations

As with all things in life, Norwich University expects your best. Academic success is the end goal for all our students. The University's founder, Capt. Alden Partridge, would expect all students to "try." This does not merely mean "giving it a shot." This means to prepare yourself, apply yourself, and follow up. If you do not reach your goals at first, it is your responsibility, and the University's expectation, that you will "try" again. Do not blindly try again but assess the situation, seek support, and succeed. Each student is unique and will face different challenges in reaching their goal. The university's faculty, staff, coaches, and student leaders are here to help you reach your goals. Utilize all available resources so you make the most of your collegiate experience.

Professional Titles...Doctor, Professor, Colonel, General, Coach, Dean and many more: At any college there are faculty and staff with academic credentials who have earned degrees for which they are recognized with a title. At Norwich we have many staff and faculty in uniform with military rank and titles based on their assignment and position of responsibility. The proper courtesy is to refer to the person by academic or military title/rank and last name, e.g. President, General or Dr. Schneider, Dr. Affenito, Senior Vice President, Brigadier General, or Dr. Vanecek, Dean Mathis or Dr. Mathis, Colonel Titus, Coach Mariano, Dean Temkin. The same would hold true if they are retired. The use of first or last names alone

is inappropriate and considered disrespectful.

Vermont State Militia (VSM) Uniform

For 200 years, the faculty of Norwich University have worn a uniform similar to that of the US Army. This tradition started with our founder, Capt. Alden Partridge. While the “Army greens,” are no longer used by the active duty or reserve components of the Army, they remain the uniform of the Vermont State Militia. Such outfitting and rank structure is defined in Vermont Law with the authority resting with the Board of Trustees and the President of the University to implement. Norwich faculty is made up of wonderfully educated and experienced individuals—some with prior military service and some without. Even faculty members who have never served in our United States military wear the uniform of the Vermont State Militia as a tradition of the oldest private military school in the nation and as a Senior Military College.

The rank structure of the VSM uniform is equivalent to a faculty member’s academic rank and is based on the amount of time it takes to reach certain academic ranks.

Dress Code: All students are expected to dress appropriate to the occasion. Examples of appropriate attire in academic buildings, administrative buildings, and the dining hall are considered e.g. slacks and a shirt, jeans and a tee shirt, jeans and a sweater and footwear. This means that no athletic clothing like swimwear, sweats, athletic shorts, or tank tops should be worn in these buildings. Additionally, sleepwear is not appropriate for these areas. These expectations are supported by policies in the University’s Rules and Regulations. If you are found violating the dress code, you may be asked to leave the facility to change clothes before you are allowed to return.

All students are expected to wear business casual or business attire for special occasions such as award ceremonies, recognition events, and when so announced. Look to the event invitation for attire guidance. When in doubt, ask the event organizer or a faculty or staff member.

Examples of business casual attire include slacks and a shirt with collar, a casual skirt and top. Examples of business attire include a jacket and tie for men and a dress or suit for women.

Wearing of Hats Indoors: As a common courtesy and form of respect the wearing of baseball caps, beanies, hoodies, etc. is not appropriate inside academic or administrative buildings, the dining hall or during formal occasions such as Convocation, guest speakers, meeting with a faculty or staff member, etc. Please remove such items once you enter the buildings. It’s not just a military thing, but common courtesy and college policy.

Academic Achievement Center (AAC)

Located on the recently renovated 4th floor of the Kreitzberg Library (Room 403), the Academic Achievement Center (AAC) is a great place to connect with professional and peer tutors who can help you work smart to achieve your academic goals. The AAC helps students improve their study, time management, organizational and learning skills, and provides academic coaching services. The AAC’s staff offers comprehensive individualized and group tutoring across the curriculum. They provide tutoring for all math courses, as well as most lab science and foreign language courses. They also provide tutoring in liberal arts content areas such as criminal justice, discipline specific study skills, and research projects. The AAC also offers English support for multilingual students, and serves students with disabilities, or in academic difficulty.

Each semester, the AAC works with about 500 students, many of whom consistently make the Dean’s List. Over 50% of the NU students who graduated in 2019 with highest honors came to the AAC at least once during their career, and many of them worked with the AAC regularly.

The AAC is open from 8:00 a.m. to 10:00 p.m., Monday-Thursday, and 8:00 a.m. to 5:00 p.m. on Fridays. All AAC services are covered by tuition; there is no additional cost to students so you should use what you've already paid for! We look forward to working with you.

Career and Internship Center

[The Career & Internship Center](#) assists undergraduate students and alumni of the University in seeking employment in a field consistent with their academic training and interests. In support of this mission, a broad range of programs and services are provided, including assistance with:

- Job and internship postings
- Internship and job search strategy
- Resume and cover-letter preparation
- Networking
- Mock interviews
- Personal branding
- Class presentations
- Career fairs and other career-related events
- Salary and compensation negotiation
-and so much more

Please contact our friendly and experienced staff to get started on your career path. We are located in 232 WCC, so feel free to stop by and make your appointment today. You can also contact us as careers@norwich.edu or by phone at (802) 485-2125.

Center for Student Success

Have a question and don't know who to ask? Need some assistance and don't know where to go? Want some advice but aren't sure where to receive it? The Center for Student Success provides the guidance, support, and advocacy for all students.

The Center for Student Success has two major areas of focus:

Overall student experience to include:

- Support during the transition to college
- Guide students to resources for social, financial, or academic well-being
- Advocate for students on a variety of issues
- Outreach to struggling students to create individualized solutions

Overall student veterans' experience to include:

- Support during the transition from the military to civilian life
- Assist in understanding, obtaining, and using military educational benefits
- Help with VA Educational Benefit certification to pay for college expenses
- Work to ensure a positive experience in the transition to collegiate academics

For more information, please contact The Center for Student Success at (802) 485-2355

Counseling & Wellness Center

The Counseling & Wellness Center provides an opportunity for Norwich University students to speak with a licensed mental health clinician in a confidential setting. Our experienced staff is available to collaborate

with you in identifying and working toward your personal goals in individual, couple, or group formats. We also sponsor fun and interactive events throughout the school year, which all students are welcome to attend. Participation in counseling services will not interfere with a current or future military career, and is free of charge.

The C&WC is located on the 4th floor of Kreitzberg Library, in room 415. Counselors typically meet with students by appointment, but walk-ins may be accommodated. Our hours of operation are from 8:00 a.m. to 4:30 p.m., Monday through Friday, and we provide after-hours crisis coverage 24/7 during the school year.

Please contact our friendly staff with any questions, and be on the lookout for upcoming C&WC events! We can be reached at (802) 485-2134, or on the after-hours crisis line at (802) 793-3093.

Office of Diversity, Equity and Inclusion, Title IX Coordinator

The Title IX Office and the Office of Diversity, Equity, and Inclusion are located in the Wise Campus Center, Room 222. This office manages compliance with state and federal laws and university policies on non-discrimination, harassment and sexual and gender based misconduct for the Norwich University community. The Norwich University Non-Discrimination Policy is found here at this [link to the non-discrimination policy](#) and the Sexual and Gender Based Misconduct Policy is found here at this [link to the sexual and gender based misconduct policy](#). If you have an issue involving any of these areas, please contact the Title IX Coordinator at (802) 485-2144. The office also works on inclusion initiatives through educational programming and prevention awareness.

Honors Program

Norwich University's Honors Program is a merit-based, highly selective program for outstanding scholars. The program supports an enriched academic experience through an applied experiential learning process. The four-year curriculum is designed to support motivated students with demonstrated academic abilities and strong interests in research, service and leadership. The capstone of the program is a senior thesis project that will lead to the distinction of Honors on the successful student's degree. For more information, please contact the Director at nuhonors@norwich.edu.

Norwich University Student Health Center

The Student Health Center (also known as the infirmary) is located on the 1st floor of Marsilius Hall on Crescent Avenue and is operated by Central Vermont Medical Center. Students have seven-days-a-week access to health care. The infirmary is staffed with board-certified family physicians, physician assistants, registered nurses and support staff.

Norwich University Student Health Center provides comprehensive medical services to students similar to what they would receive at their primary care office, including X-ray, labs and orthopedic care. The student health fee will cover the basic primary care such as the office visit, but all procedures (e.g., x-rays, lab work, orthopedic care, ...) will be billed to the student's personal health insurance. The Student Health Center does not house students overnight.

SERVICES OFFERED AT NUHS:

- Illness evaluation
- Injury evaluation
- Women's healthcare
- Sexually Transmitted Infection (STI) testing, treatment and education

- Nutritional counseling
- Access to necessary medications, with prescription delivery available through Northfield Pharmacy

Note: If a student is under 18 years old, they will need to sign a Consent to Release Information before we are able to speak with family members regarding their treatment.

Hours of Operation:

Walk-in nursing care: M-F 6:30 a.m. - 10:00 p.m.; Appointments with providers: M-F 7:00 a.m. - 5:00 p.m.; Weekend hours are from 8:00 a.m. – 12:00 p.m.

Phone: (802) 485-2552 ■ fax: (802) 485-4577 ■ nuinfirm@norwich.edu

Information Technology Services

Norwich ITS provides both wired and wireless internet to students. Wireless is available across campus, though students are still encouraged to use the wired network in the residence halls. Each residence hall room is equipped with enough working ports for each occupant. Additionally, Norwich is no longer offering phone service in the residence halls, with the exception of emergency residence hall phones located on the main floor.

Norwich University has three computer lab facilities available to all students, faculty and staff which are located in Juckett Hall (U-Building), Cabot Science Center (U-building), and North Hall. Additional public access computers are located in the Wise Campus Center and the mezzanine of Kreitzberg Library. Lab consultants are available during evening and weekend hours. Their responsibility is to provide assistance to students with regard to using lab facilities and answering basic questions regarding the software available. University E-mail system and the Internet is available from every PC. Standard personal computer software is available in all computer labs.

Labs will be open for student use during the day when no academic class has reserved the lab. Library lab facilities are also available during library hours. Users may contact the HELP DESK at (802) 485-2456 for assistance with issues they are having with connecting to the internet, network issues, and assistance with your university assigned iPad as a part of the Digital Citizen program.

International Center

The International Center, under the leadership of the Assistant Vice President for International Education, is responsible for partnering with a wide range of internal and external stakeholders to advance the comprehensive internationalization of the university. This work takes place over a broad range of domains, including but not limited to the following:

- **Education Abroad** - The International Center provides a wide range of programs and services related to students seeking, engaged in, or returning from education abroad programs. Numerous programs at Norwich are now offered to give students the opportunity to study abroad, including an international program for architecture, visual arts, history, political science and international studies at CityLAB:Berlin in Germany's capital. Norwich Expeditions are cohort-model programs offered in the U.S. Virgin Islands, and several locations in Europe as well as in Washington, D.C. and Denver, Colorado.
- **International Students** - The International Center provides a wide range of programs and services related to the full life cycle of an international student, including but not limited to issuance of initial immigration documents, pre-arrival outreach and communications, orientation and ongoing social and cultural programming, immigration advising, and general support services and programs to ensure academic success and retention.

- **International Scholars** - The International Center facilitates the process of bringing international visiting scholars to the university to engage in joint teaching and/or research projects with the faculty.

They can be reached at (802) 485-2934 or by stopping by their office in Plumley Armory Office #305 during regular business hours.

Kreitzberg Library

The Kreitzberg Library offers a vast array of resources and services. Through the [Keitzberg Library website](#) you can discover books, articles, videos, specialized databases, research guides, and much more. The library offers a variety of spaces for individual and group study, with abundant technology for digital collaboration. There are many computers for student use, wireless network access, and a café serving coffee, smoothies, and freshly prepared lunch items. Reference librarians are available to offer research assistance and can be contacted by email at library@norwich.edu, online chat, in person at the Library Services Desk, or by phone at (802) 485-2179. Both individual and group library instruction can be arranged by appointment. The Interlibrary Loan Department can obtain materials from other libraries if we do not have them here. See the library's website for all policies and hours of operation. The Library Services Desk can be reached at (802) 485-2176.

Norwich University Archives and Special Collections on the 5th floor of the Kreitzberg Library provides access to the library's rare book collection, as well as written records and photographs documenting the history of Norwich and the accomplishments of its alumni, faculty, staff, and students. Detailed information about archival collections can be found on the [archives website](#). Visits from students are welcome and research with the collections encouraged. Archives staff can be reached at (802) 485-2947 or archives@norwich.edu.

The Sullivan Museum and History Center, a 16,000 square foot building designed for both permanent and rotating exhibits, contains a theater, exhibit preparation areas, offices, and an instruction room. Since 2016, it has been a Smithsonian Affiliate ® museum. This modern facility is dedicated to the interpretation of the Norwich University story, the careful preservation of the University's rich history, and has a collection of over 15,000 objects. Explore the [museum website](#) for upcoming, current and past exhibitions and follow us on [Sullivan Museum's Facebook page](#), facebook.com/SullivanMuseum/.

Registrar's Office

The Registrar's Office is located in Jackman Hall in room 328. The Registrar's Office is where all student academic record processing takes place. Services provided by the Registrar's Office may be found on the [Registrar's Office web page](#) along with required forms that may be downloaded. Staff is available to answer questions regarding grades, transcripts, class schedules, final exams, graduation requirements and more during office hours. Students may only change their permanent address via completing a Change of Address form and submitting it with all necessary documentation to the Registrar's Office. The Registrar's Office is open regular business hours and can be reached at (802) 485-2035.

Religious Services

Norwich University, a non-sectarian organization, provides religious services in White Chapel throughout the year. Two Catholic masses and at least one Protestant worship service are conducted weekly. One part-time Catholic Priest and one full-time Protestant Chaplain are available on campus. An Islamic prayer room is located in the basement of the Chapel. Jewish students may visit a synagogue in nearby Montpelier (Beth Jacob) as well as Stowe (JCOGS: Jewish Community of Greater Stowe). Several other synagogues are available but are geographically farther away.

Other local houses of worship for different faiths and denominations, with contact information, are listed

on a brochure located in the literature rack in the back of the Chapel sanctuary. Many religious groups offer students free transportation to services. Further information can be obtained by contacting University Chaplain, Rev. William S. Wick in the Chaplain's Office. (802) 485-2128 / wwick@norwich.edu)

Center for Writing

The Center for Writing is a welcoming space where Norwich's writers—students, faculty, and staff—come together to talk about writing.

We provide free, one-to-one consulting, as well as small group workshops. Our peer consultants are trained to work with writers on a variety of writing projects—academic, creative, professional, digital—at all stages of the writing process. Whether you need help brainstorming ideas for a history paper, organizing a lab report, or developing characters in your next novel, our consultants guide can help guide you through that process by listening to your concerns, asking thoughtful questions, and providing examples and suggestions tailored to your needs.

We strongly encourage you to make an appointment through our website, (norwich.mywconline.com/), but we also accept walk-ins when we have consultants available. You can find us in North Hall. Feel free to drop by Sunday-Thursday from 3:00-8:00 p.m.

You and Your Academic Advisor

As a student, you are responsible for your academic progress at Norwich. You are expected to know the graduation requirements that apply to you, your major, and to take the courses necessary to meet them. Monitor your GPA regularly and decide when to add or drop a course or change your major. If you earn a low GPA your first semester, you will have to make some tough decisions that will have a big impact on your life at the University and after you graduate. Don't try to make those decisions by yourself - they're too important. Seek assistance from your academic advisor, and other resources to develop a plan to improve your GPA, because it may take several semesters to significantly improve your cumulative GPA. Your advisor is responsible for helping you understand University policies, procedures, and requirements. He or she can help you assess your academic problems and make the best decision about how to overcome them. Most important, your advisor can help you get the most out of your college education. But there's a catch - you have to ask for your advisor's help. It's your responsibility to seek the advising you need.

How to get the most out of your advisor:

1. See your advisor regularly throughout the semester, not just when you want to register for courses.
2. Make appointments with your advisor at a time convenient for both of you, before problems surface, or soon thereafter.
3. Discuss with your advisor your educational and professional goals. Be honest about any learning issues you may have. Don't withhold information or assume that your advisor knows everything about you.
4. Be assertive. Ask questions. Don't assume that your advisor will automatically know what you need.
5. Review the Academic Regulations and your academic record at the start of each semester. If you spot a problem, point it out to your advisor immediately.
6. Your advisor wants to help you succeed in college, use him/her.

Good academic advising can make a big difference in your college career. But remember: a successful working relationship with your advisor depends on both of you. Without your initiative, your advisor can't help. If you want to change your advisor or discuss a problem you have with your advisor, see your department chair.

COMMUTER STUDENT LIFE

General

Commuter students constitute a vital part of the Norwich University community and are eligible to participate in campus services and activities. The Associate Dean of Students Office, located in the Wise Campus Center (WCC), Room 227, is available to assist commuter students with concerns and to provide information about campus services. Commuter students are subject to all University policies and rules and regulations. A complete copy of the NU Student Rules and Regulations is available from the Associate Dean of Students, at the library, and on my.norwich.edu under “University Policies”.

Off-Campus Housing

The Associate Dean of Students serves as an advocate for all civilian commuter students; however, it is important that all commuter students are aware of local ordinances—we expect you to live off campus as responsible, lawful citizens of the community. The Assistant Dean of Students works with the local officials to maintain open lines of communication and to make sure that our students are respectful and valued members of the local community.

When students choose to attend Norwich University they accept the rights and responsibilities of membership in the University’s community. As such, members of the University community are expected to uphold our Guiding Values regardless of whether they reside on campus, live off campus, or commute from home. In our Guiding Values, we state: “We stress self-discipline, personal responsibility, and respect for law.” While on-campus behavior is the direct responsibility of the University, there are circumstances when the administration shall address off-campus behavior that negatively impacts the community or the University. Such behavior is in conflict with the University’s values and may warrant direct intervention by the Associate Dean of Students.

Registration of Local Address and Phone

It is often necessary for someone at the university to contact a commuter student. As part of your registration process, or returning student in-processing, all commuters are required to register your local address and local phone number in Banner Web or with the Registrar’s Office in Jackman Hall, 3rd Floor. If changes occur in your permanent address, you must inform the Registrar’s Office using a “Change of Address” form. This form can be printed from the NU Registrar’s website or is available outside their office in Jackman Hall, Room 328. Also during your student in-processing you will be required to provide a cell phone number and/ or email address for the RAVE Emergency Alert System. This system will notify you by either text or email should there be an emergency on campus. It is the university’s priority to keep its student safe and the RAVE Alert System is one of the quickest and most effective means of getting information to students during an emergency situation.

Campus Services for Commuter Students

All university services are available to commuter students. Norwich University encourages our commuter students to take full advantage of their opportunity to actively engage with the campus community and partake in the different events, services, and experiences the campus offers. The university provides volunteer opportunities through the Center for Civic Engagement (WCC, Room 230), professional development opportunities and information through the Career and Internship Center (WCC, room 232), tutoring services through the Academic Achievement Center (Kreitzberg Library, Room 403), social activities/events which are planned by the student run Campus Activity Board (CAB), Fitness Center & cardio workouts (Plumley Armory), computer labs, athletic events, and more. Convenient, support services that may be of special interest to the commuter population include the following:

1. All NU Student Health Services. All full time commuter students pay for and have the same use of the

Student Health Services as Corps and civilian residential students. The Norwich University Student Health Services is available to all fee paying students during the academic year. It is located across from campus on the first floor of Marsilius Hall (63 Crescent Avenue, Northfield, VT 05663). Students can be seen on a walk-in basis and by appointment. Appointments with providers are available Monday–Friday from 7:00 a.m.–7:00 p.m. and weekends from 9:00 a.m.-11:00 a.m. Walk-in nursing care is available from 7:00 a.m.–10:00 p.m., Monday-Friday and weekends 8:00 a.m.-12:00 p.m. Services provided by the Student Health Services are similar to those that you would go to your doctor or family practice provider for.

SERVICES OFFERED AT NUHS:

- Illness evaluation.
- Injury evaluation.
- Women’s healthcare.
- Sexually Transmitted Infection testing, treatment and education.
- Nutritional counseling.
- Access to necessary medications, with prescription delivery available through Northfield Pharmacy

Services provided are at no charge to the student with the exception of lab work, diagnostic imaging, procedures and durable medical equipment. The Student Health Center can be reached at (802) 485-2552 or nuinfirm@norwich.edu.

2. Lockers. Lockers are available to commuter students in the Wise Campus Center (WCC) and are located near the NU mailroom on the ground floor. Students who wish to reserve a locker should contact the Assistant Dean of Students to sign out a key and complete a locker agreement form. There is no fee for using a locker but you must have your Norwich ID and a contact phone number in order to sign out a key for a locker. Keys must be returned when you graduate or are no longer enrolled as a student at Norwich University. Keys that are lost or are not returned will result in a \$35.00 replacement fee.

3. Commuter Information Board. Campus information and announcements are posted on the bulletin board located in the WCC “Sky Box” lounge located on the top floor of the building.

4. NU Mailroom. There are currently no mailboxes available for commuter students. You can however buy stamps and send out mail via USPS.

5. Meal Plan. Off-campus meal plans are available for commuter students through Sodexo Food Services that include a number of all you can eat meals in the WCC Dining Hall and varied spending amounts that can be used at the Mill Snack Bar, Dunkin’ Donuts, and the Daily Grind Cafe. Many commuter students use The Mill Snack Bar as a “hang out” between classes. For further information, contact Sodexo at (802) 485- 2298, Wise Campus Center, Room 108, or <https://norwich.sodexomyway.com/>.

6. Print Services. Printing services are available in the WCC at the Copy Center on the ground floor across from the NU Mailroom. The Copy Center provides both black and white and color copying for students, faculty, and staff and is less expensive than off-campus copy centers.

7. Check Cashing. In addition to providing apparel, textbooks and convenience store items, the Norwich University Bookstore (WCC, ground floor) offers free check cashing up to \$100 with a photo ID. The Bursars office will also cash a personal two-party check up to \$150 and Norwich University checks (work study paycheck, etc.) for the full amount.

8. Commuter Facebook Group. A Norwich University commuter Facebook group page has been established to help keep commuters aware of events taking place on campus and to provide a means for commuter

students to communicate with one another about issues or with questions. The group name is “Norwich University Commuters.”

9. Weekly Commuter Newsletter: The Cadet Suburbanite. The Cadet Suburbanite was established in response to commuter students’ feedback and desire to know what is happening on campus. Each Monday a newsletter is emailed out to commuter students at their Norwich email address. Social events, athletic events, lectures, job opportunities, volunteer opportunities, important dates, and more are all covered in this weekly newsletter.

10. Refrigerator. There is a refrigerator on the top floor of the Wise Campus Center, near the Skybox Lounge, for commuters to use. This is made available so commuters can store food and beverages during their classes.

Parking and Car Registration

All student vehicles must be registered with NU Public Safety. Students must provide a valid driver’s license, vehicle registration and proof of insurance in order to receive a parking pass. The cost of registering your vehicle is \$350/academic year (subject to change). Tickets are at a minimum of \$30 each. Commuter students may park in the following parking lots: F, G, Plumley Armory, and Kreitzberg Arena. Commuter students may park in “Visitor Parking” at Jackman Hall only for the purpose of conducting business at Jackman Hall. Commuter students are highly encouraged to park in designated university parking lots and not on the streets of Northfield. NU Public Safety will provide additional information about parking when you register your vehicle. In an effort to keep drivers and pedestrians safe, please note that the campus has a 15 miles’/hour maximum speed limit. For further information, please see the Student Motor Vehicle Rules and Regulations.

Temporary parking changes (such as for snow removal or construction) are posted to the campus community via my.norwich.edu.

Inclement Weather Policy

Classes will meet unless the president issues a cancellation notice. Students should be prepared to come to class; excused absences are not available except in extreme cases. All commuter students should review your course syllabi at the beginning of each semester for each course’s attendance policy. Additional information about excused and unexcused absences can be found in the university catalogue under “Academic Policies” and then under “Attendance & Cancellation of Classes”. Contact the professor as soon as possible via email or phone if you miss class due to inclement weather to see how, or if, the class can be made up. Should classes be canceled or delayed for the entire campus due to severe weather, you would be informed through the RAVE Emergency Alert System.

Ring Policy

The commuter student policy is the same as the policy for Residential Civilian Students. Please see Chapter 5.

THE CORPS OF CADETS AND ROOKDOM

Approximately two-thirds of the students who attend Norwich choose to be in the Corps of Cadets. The Corps lifestyle is characterized by a rigid and high set of standards which are expected of every cadet on and off campus. Cadets are indoctrinated to this lifestyle through training, customs, courtesies, uniforms, formations, and inspections. Cadets learn how to be leaders in their professional lives through the application of a four-year progressive leadership model which advances cadets from basic skills and knowledge in leadership through the application of skills as a leader in the Corps. It all starts with “Rookdom.”

The Recruits (“Rooks”), or first year cadets, undergo a period of initial entry training called “Rookdom.” Rookdom is a mentally and physically challenging experience designed to develop recruits’ abilities to organize, manage time and stress, pay attention to detail, develop physical fitness and mental toughness, and to instill in each cadet the bedrock values of courage and confidence which are essential for their development as a leader of character. Rooks must first learn to be good followers before they become leaders in their upper class years. They are trained by cadet cadre, who are primarily third year cadets and upper class leaders.

We want all rooks to succeed and the entire community can help; including you. If you see a Rook who is struggling, visibly upset and possibly even in tears, encourage them to persevere, to seek help through their chain of command or to take advantage of the support services on campus. If you are very concerned, please identify the name of the Rook and inform a faculty member, a cadet leader, or a member of the Commandant’s staff.

Conversing with Rooks: The Rooks have many rules to follow. One rule is that while outside or in the dining hall, they are to be “locked-on” meaning focused, looking straight ahead, walking and not conversing with anyone unless greeting an officer or cadre member. Please support this policy and do not talk with rooks while they are “locked on.” You may talk with them inside academic buildings and athletic facilities (and we encourage you to do so).

Military Formations/Ceremonies & Common Courtesies

Military customs and courtesy are a manifestation of the values we cherish as a Senior Military College and a nation. They are intended to reinforce discipline, obedience to authority, patriotism, duty and dedication, and membership in the military lifestyle. All cultures have customs and courtesies. We ask that all students respect our customs and courtesies as a way of honoring military service, our national symbols, and our university’s military heritage.

Upper Parade Ground (UP)

As a military college our cadets experience daily military formations, special reviews and ceremonies throughout the year. Similar to civilians who work on military installations, there are some courtesies that should be observed regardless of lifestyle because you are an American citizen and have chosen Norwich. Below are several military events and bugle calls where courtesies are expected of all students, faculty, and staff members.

Reveille – Reveille is the first bugle call of the day and signifies when the national flag is being raised. This occurs daily at approximately 7:45 a.m. Often a cannon fire will signal the start of the bugle call.

Retreat and To the Colors– The lowering of the flag at the end of the duty day, typically at 5 p.m., is signified by two bugle calls. The first, *Retreat*, is played before the flag is lowered. Normally, a cannon is fired on the last note of *Retreat* which is then followed by the second bugle call, *To the Colors* which is played as the flag is lowered.

“*Taps*” / *Echo Taps* – bugle call honoring a deceased military member or official at a ceremony. At Norwich, we may also render such honors for a deceased student, faculty or staff member. Evening “*Taps*” played daily by a bugler at 10 p.m. signals the end of the day and requires no response, though you may want to pause and reflect.

Honors & Ruffles and Flourishes – Military honors to a general or flag officer or select state officials during a parade or special ceremony. The band will play “*Ruffles and Flourishes*” and, if warranted, artillery unit will fire several cannon volleys.

What should you do if you are outside and you hear one of these songs?

1. Do not ignore, or run and move inside to avoid rendering proper courtesies.
2. Stop and remove hat/earphones, as applicable.
3. Face in the direction of the flag pole on the UP.
4. Do not talk or converse during the music.
5. Stand erect and place your hand over your heart until the music has ended

Note: When in doubt, observe what cadets and college officials are doing. If they are standing and saluting during a bugle call or song, you should stand straight, remove any hat/earphones, and place your hand over your heart.

Passing of a Color Guard: When you see a Color Guard passing by you (cadets carrying the US and other flags with two rifle bearers), stand erect, remove your cap/earphones, and place your hand over your heart until the Color Guard passes. The same would be true if the Color Guard is not in a parade and you happen to pass by one.

Corps Formations: If you find yourself on the UP when the Corps is forming up, do not cross along the bricks or other pathways that cross the UP. Instead, please walk around the formation. If the Corps is marching in a parade do not cross in between units of the parade. Walk along side or wait until the Corps has marched by before you cross.

Tour Strip: At the top of the UP there is a strip of asphalt near the flag pole and canon called the Tour Strip. This is not a general walkway, but reserved for Cadets to march disciplinary tours when they have violated certain rules.

Military/Corps of Cadets Vernacular

Barracks.....	Residence Hall that houses cadets
Cadre.....	Cadet leaders who are responsible for training Rooks
Commandant.....	Professional Staff Member who is responsible for the Corps of Cadets
Chow Hall.....	Dining Hall
Cover.....	Hat/headgear
Deck.....	Floor (Navy vernacular)
Latrine.....	Bathroom (Army vernacular)
Mess.....	Meal served
Head.....	Bathroom (Navy vernacular)
Headgear.....	Hat worn as a uniform item
Rack.....	Bed
Rook.....	First year cadet not recognized into the Corps of Cadets
Tours.....	Disciplinary sanction that is 50 minutes of marching with rifle on a tour strip
Mil Lab.....	Military Lab

Military/ 24- Hour Time

0100 - 1 a.m.	0900 - 9 a.m.	1700 - 5 p.m.
0200 - 2 a.m.	1000 - 10 a.m.	1815 - 6 p.m.
0300 - 3 a.m.	1100 - 11 a.m.	1900 - 7 p.m.
0400 - 4 a.m.	1200 - noon	2000 - 8 p.m.
0500 - 5 a.m.	1300 - 1 p.m.	2130 - 9:30 p.m.
0600 - 6 a.m.	1400 - 2 p.m.	2200 - 10 p.m.
0700 - 7 a.m.	1500 - 3 p.m.	2300 - 11 p.m.
0800 - 8 a.m.	1600 - 4 p.m.	2400 - midnight

The Corps of Cadets is organized in a military organizational hierarchy, which includes (from lower organization to higher) Squads, Platoons, Companies, Battalions and the Regiment (Corps). Rooks are assigned to one of the five Cadet Training Companies (CTCs) while upper class cadets are assigned to a leadership position or one of the lettered companies (A – D Co.)

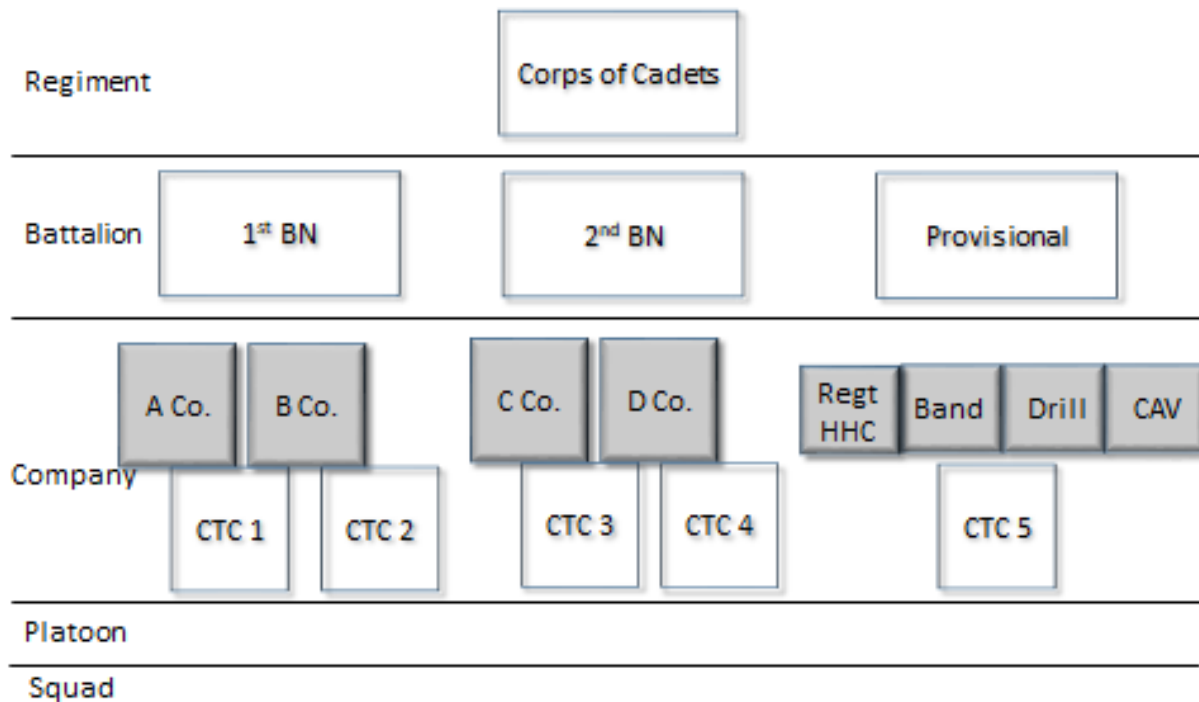

ACTIVITIES & INVOLVEMENT

Athletics/Recreational Facilities

Norwich University currently fields 18 NCAA Division III varsity athletic programs, and two varsity rugby programs (men's program is Division II and women's program is Division III).and a variety of intramural activities. Club sports can be organized with sufficient student interest through the Student Activities Office, (802) 485- 2121. The Intramural Program provides students an opportunity to compete in a wide range of activities to include soccer, volleyball, dodge ball, basketball, ice hockey, whiffle ball and softball. These activities are seasonal and take place during the normal practice hours for athletic teams.

Norwich University's athletic facilities include Andrews Hall, Shapiro Field House, Plumley Armory, Kreitzberg Arena, Sabine Field, Howard Field, Garrity Field, Rugby Field, Softball Field, Shaw Outdoor Center, and practice fields.

Campus Activities Board

The Campus Activities Board (CAB) is a student-run organization, open to all NU students, responsible for programming a wide array of student events and activities on and off campus, and provides leader development opportunities for students. CAB leaders are engaged in planning and executing major University events, including the Regimental Ball, Parent & Family Weekend, Winter Carnival, and Junior Ring Weekend and Intramural Sports Tournaments. For more information about the CAB and student activities at Norwich University, email cab@norwich.edu, or visit the Student Activities Office on the 2nd floor of the Wise Campus Center (WCC 228). Facebook/Instagram @norwichcab.

Center for Civic Engagement

The Center for Civic Engagement (CCE) organizes one-time and ongoing local, national and international volunteer and service-learning opportunities for students, faculty, staff and alums.

The Center is also responsible for programs such as Alternative Breaks, NU VISIONS Abroad, the Civic Scholars Program, and the Community Service Work-Study Program. Student service organizations sponsored through the CCE include: Unify (Special Olympics Club), NU Emergency Medical Services (NUEMS), Rotaract, Buddy Up Youth Mentoring, NU Scouting Association (NUSA), Violence Intervention Peer Advocates (VIPA), and collegiate chapters of Amnesty International, Habitat for Humanity and Girls Who Code. The CCE also sponsors or hosts special events and services such as the Annual Blood and Bone Marrow Registration drives, the Clothing Drop 'n Swap, Trash to Treasure, the Legacy March, Days of Service, book drives, Volunteer Income Tax Assistance, and the Angel Tree, among others.

To learn more about volunteer opportunities offered throughout the week, visit getconnected.norwich.edu/. The CCE is located in Wise Campus Center, 2nd Floor, Room 230 and staff can be reached at (802) 485-2644 and 4achange@norwich.edu.

Leadership Development Program

At some point in our lifetime we are all called to lead. To take responsibility, to put others first, to serve our country, our community, our family. To inspire others to follow, whether in the classroom, a corporation, a hospital, a service organization, or the military.

A required, one-credit online seminar for all students, LD101-Principles of Leadership, will help you define and understand leadership, examine personal leadership mastery, and adapt your personal capacity for leading in today's world. This requirement may be completed at any time prior to graduation.

Additionally, you may sign up for voluntary leadership seminars and activities throughout your years at Norwich to further prepare you for your future. The Leadership Development portal at OrgSync will be your up-to-date guide for leadership programming and activities.

If you have any questions, please don't hesitate to call or email Tracey Poirier, AVP for Leadership and Student Engagement at (802) 485.2225 or tpoirier@norwich.edu.

Shaw Outdoor Center

Built in 2013, the SFC John Shaw Outdoor Center (aka the SOC) is your base for outdoor activity on campus. The SOC maintains a fleet of mountain bikes that are free for students to borrow during business hours along with a variety of outdoor equipment. You can take out a pair of snowshoes or cross-country skis in the winter or grab a few discs to play a round of disc golf when the weather is nice. Additionally, students can check out camping equipment, headlamps, and the ever popular rocket sleds, all free of charge. There are several miles of maintained and groomed trails for running, hiking, biking, cross-country skiing, snowshoeing and sledding depending on the season. The SOC also runs rock/ice climbing and caving trips during the year so join our Facebook page to be the first to know. [Facebook.com/norwichSOC](https://www.facebook.com/norwichSOC). The facility is located at the base of Paine Mountain, across Route 12 from campus.

Student Clubs

In a typical semester, roughly 50 student clubs are recognized and active through the Student Activities office. Students are encouraged to get involved with a variety of existing clubs or to engage other students by starting a new club. For an up-to-date list of student clubs, to form a new club, or for any other student club related questions, email studentclubs@norwich.edu, or visit the Student Activities Office on the 2nd floor of the Wise Campus Center (WCC).

Student Government Association (SGA)

The Student Government Association (SGA) at Norwich University is run by our students for our students. The SGA is one of three "shared governance" bodies recognized by the University Administration – the other two being the Faculty Senate and the Staff Council.

Elected student leaders work to enhance campus life and act as liaisons for students to faculty, administration and alumni. SGA leaders also review student club applications and participate with various University committees. The SGA has two bodies: (1) the executive branch with the elected student body President, Vice President and Treasurer, and appointed staff members; and (2) the Student Senate which is the legislative branch.

The SGA is always looking for new members and new ideas. Email nusga@norwich.edu to get involved and to ask questions or share concerns.

CAMPUS SERVICES

Barber Shop

The NU Barber Shop is conveniently located on the NU campus in the brick building located in the Kreitzberg Arena parking lot. The entrance is located on the south side of the building. The NU Barber Shop is open Monday – Friday from 8:00 a.m.-4:30 p.m. with the last customer taken at 4:00 p.m. They are closed during University breaks. They are available on a walk-in basis and do not accept appointments.

Long Hair = \$18

Short Hair = \$14

Payment is in cash only.

Bursar

The Office of the Bursar is responsible for generating the student tuition bill, issuing financial clearance for enrollment, and enforcing the university fees and financial policies. To better serve you, the University has established electronic billing and online payments are available to Norwich University undergraduate students and their designated family members or guests. Go to the Bursar's website at norwich.edu/bursar to learn more about the conveniences NUpay provides.

Their services also include check cashing and notary services. The account counselors of the Office of the Bursar help students and their parents with assistance in understanding your student account and ensuring that your financial responsibilities are met.

The Office of the Bursar is located in Jackman Hall, Room 204. They are open Monday-Friday from 8:00 a.m.-4:00 p.m. to assist you in person or by phone. The phone number is (802) 485-2055. They can be emailed at nubursar@norwich.edu.

Cadet\$Card

All students are required to have a Norwich University identification card (Cadet\$Card). Your student ID provides swipe access for eating in dining halls, entering campus buildings, cashing checks, checking out books, using athletic facilities, accessing buildings, reserving equipment from the Wise Campus Center (WCC 213) and SOC, and for admission to campus activities. The Cadet\$Card can also be used as a debit card at several on and off campus businesses. Visit the [Web Card Center](#) to add money or to check your balance. Each student receives a free ID upon enrollment. Visit the Student Activities Office on the 2nd floor of the Wise Campus Center (WCC 213) to replace a damaged or lost card. Questions? Please call the office via telephone (802) 485-2840 or email cadetscash@norwich.edu.

Dining & Catering Services by Sodexo

The Sodexo office is located in Wise Campus Center (WCC), room 108. The staff can help you with nutritional services, catering, and special event needs for individuals and campus groups. A food service manager is available during every meal to answer questions or address concerns. If you have a food allergy, please stop in their office to make arrangements to speak to a chef your needs can be addressed. Food and beverages prepared for service in the dining hall may not be taken from the dining hall. Students may request a box lunch when participating in off-campus internships, clinical, field trips, or if similar commitments prevent them from eating in the dining hall. Their business office is open Monday through Friday from 8:00 a.m. - 4:30 p.m. and they can be contacted via telephone, (802) 485-2297. Appropriate dress in the dining hall is required. Please refer to the Norwich University Student Rules and Regulations: Chapter 3, Dress and Grooming Standards.

Please visit the [dining website](#) for more information.

Fitness Center, Goodyear Pool, & Kreitzberg Ice Arena

The hours of these services can fluctuate from semester to semester. You can find the current hours by going to my.norwich and selecting [Hours for NU Services](#).

Laundry Services through the Uniform Store

Laundry services are billed by semester or by year through the uniform store located in the Hayden Building. See the uniform store for detailed costs.

Personal Laundry Service:

Norwich will wash, dry, and fold your personal laundry (sweats, underwear, T-shirts, shorts, socks, jeans, etc.) every week that school is in session. The service will be provided with a 1-2 day turnaround.

Bed and Bath Linen Service:

Norwich will provide you with 4 flat sheets, 2 pillow cases, 6 towels, and a pillow. Norwich will wash, dry, and fold the linens provided every week that school is in session. The service will be provided with a 1-2 day turnaround.

Mailroom

The Norwich University Mailroom is located on the ground floor of Wise Campus Center (WCC) and offers a wide variety of services such as selling stamps, envelopes and much more. The Mailroom can ship items through the United States Postal Service as well as UPS. Mailroom personnel sort and distribute your incoming mail and provide a morning and afternoon pickup of outgoing mail. They are open Monday through Thursday from 8:00 a.m. - 4:30 p.m. and Friday from 8:00 a.m. – 4:00 p.m. Student's mailing address should be formatted as follows:

Student's First & Last Name
158 Harmon Drive
NU Box # _____
Northfield, VT, 05663

Public Safety

The Norwich University Office of Public Safety works to assure the safety and security of all students, University employees and visitors. Public Safety is not a police force. Rather, the Public Safety staff works closely with the Dean of Students and Commandant and their staff to ensure that University policies and procedures related to safety, security, parking and crime prevention are followed. More specific information can be found on the University website. The NU Office of Public Safety is located on the backside of the Hayden Building and is available 24 hrs. a day/7 days a week. They can be reached at (802) 485- 2499 or (802) 485-2525. The current Campus Security Safety and Fire Safety report is found on the [University's website](#) and is also available from the Public Safety Office and the Dean of Student's Office. The Public Safety website is available at www.norwich.edu/public-safety/.

Office of Financial Aid

The office of Financial Aid helps you navigate the process of funding your education. They can assist you with questions regarding your financial aid package, work study positions, filing the FAFSA, and questions related to loans, grants and scholarships.

It is important to familiarize yourself with the different financial aid forms and deadlines. The staff's job is to make the task as painless as possible while still following federal guidelines. They are available in

Jackman Hall, Room 302 Monday-Friday: 7:30 a.m.-4:30 p.m. They can be reached at nufinaid@norwich.edu or (802) 485-3015.

UNDERGRADUATE CALENDAR

Norwich University posts an online master calendar that includes all campus events, found on the public website as well as on my.norwich.edu, calendar.norwich.edu. Also available online is an academic calendar showing specifically academic dates and events, found here: norwich.edu/about/1331-academic-calendar
See also the Alumni and Family's Relations Office's Calendar Card

NU EMERGENCY 24-HOUR PHONE NUMBERS

Emergency: 911

Washington County Mental Health Services Crisis Line: (802) 229-0591

Sexual Assault Crisis: (802) 479-5577

National Suicide Prevention Lifeline: 1 (800) 273-TALK (8255)

Counseling Center After-Hours Crisis Line: (802) 793-3093

NU Infirmary: (802) 485-2552

Northfield Police: (802) 485-9181

NU Public Safety: (802) 485-2525 (Emergency), (802) 485-2499

NU Chaplain Cell Phone: (802) 272-0585

NU STUDENT RESOURCE DAYTIME PHONE NUMBERS:

Counseling & Wellness Center: (802) 485-2134

NU Chaplain: (802) 485-2128

NU Equal Opportunity/Title IX: (802) 485-2144

Center for Student Success: (802) 485-2355

Academic Achievement Center: (802) 485-2130

Dean of Students Office: (802) 485-2640

Office of Residence Life: (802) 485 2643